

Construction Pro Series

Passes through standard doorways in the tilt-back position

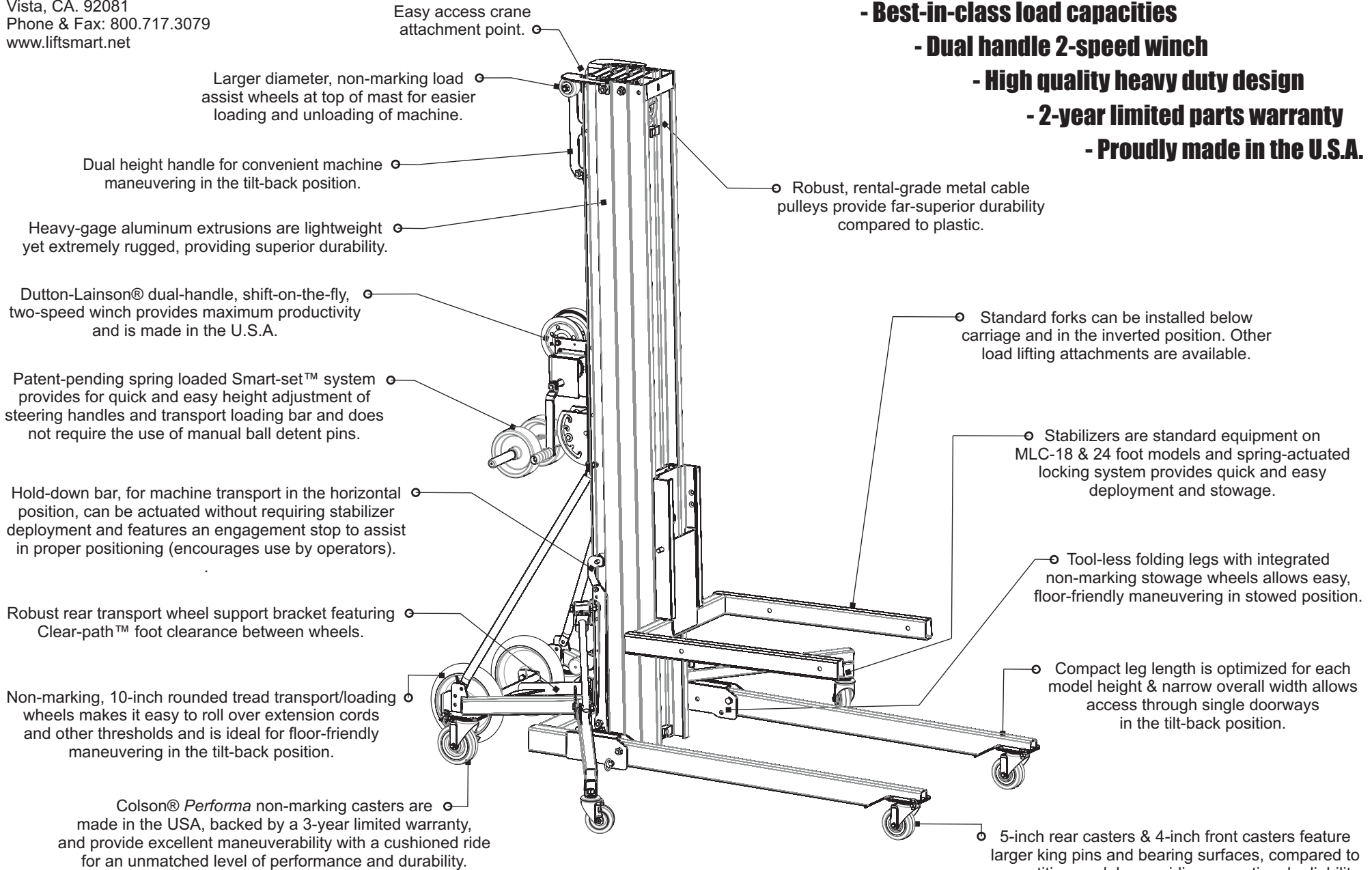

- Best-in-class load capacities

- Dual handle 2-speed winch

- High quality heavy duty design

- 2-year limited parts warranty

- Proudly made in the U.S.A.

Easy access crane attachment point.

Larger diameter, non-marking load assist wheels at top of mast for easier loading and unloading of machine.

Dual height handle for convenient machine maneuvering in the tilt-back position.

Heavy-gage aluminum extrusions are lightweight yet extremely rugged, providing superior durability.

Dutton-Lainson® dual-handle, shift-on-the-fly, two-speed winch provides maximum productivity and is made in the U.S.A.

Patent-pending spring loaded Smart-set™ system provides for quick and easy height adjustment of steering handles and transport loading bar and does not require the use of manual ball detent pins.

Hold-down bar, for machine transport in the horizontal position, can be actuated without requiring stabilizer deployment and features an engagement stop to assist in proper positioning (encourages use by operators).

Robust rear transport wheel support bracket featuring Clear-path™ foot clearance between wheels.

Non-marking, 10-inch rounded tread transport/loading wheels makes it easy to roll over extension cords and other thresholds and is ideal for floor-friendly maneuvering in the tilt-back position.

Colson® *Performa* non-marking casters are made in the USA, backed by a 3-year limited warranty, and provide excellent maneuverability with a cushioned ride for an unmatched level of performance and durability.

Robust, rental-grade metal cable pulleys provide far-superior durability compared to plastic.

Standard forks can be installed below carriage and in the inverted position. Other load lifting attachments are available.

Stabilizers are standard equipment on MLC-18 & 24 foot models and spring-actuated locking system provides quick and easy deployment and stowage.

Tool-less folding legs with integrated non-marking stowage wheels allows easy, floor-friendly maneuvering in stowed position.

Compact leg length is optimized for each model height & narrow overall width allows access through single doorways in the tilt-back position.

5-inch rear casters & 4-inch front casters feature larger king pins and bearing surfaces, compared to competitive models, providing exceptional reliability.

**NEARLY 100% U.S. CONTENT
INVEST IN AMERICA - CHOOSE LIFTSMART**

Industrial Pro Series

Passes through standard doorways without tilting back

- Heavy-duty load capacities

- Dual handle 2-speed winch

- High quality robust design

- 2-year limited parts warranty

- Proudly made in the U.S.A.

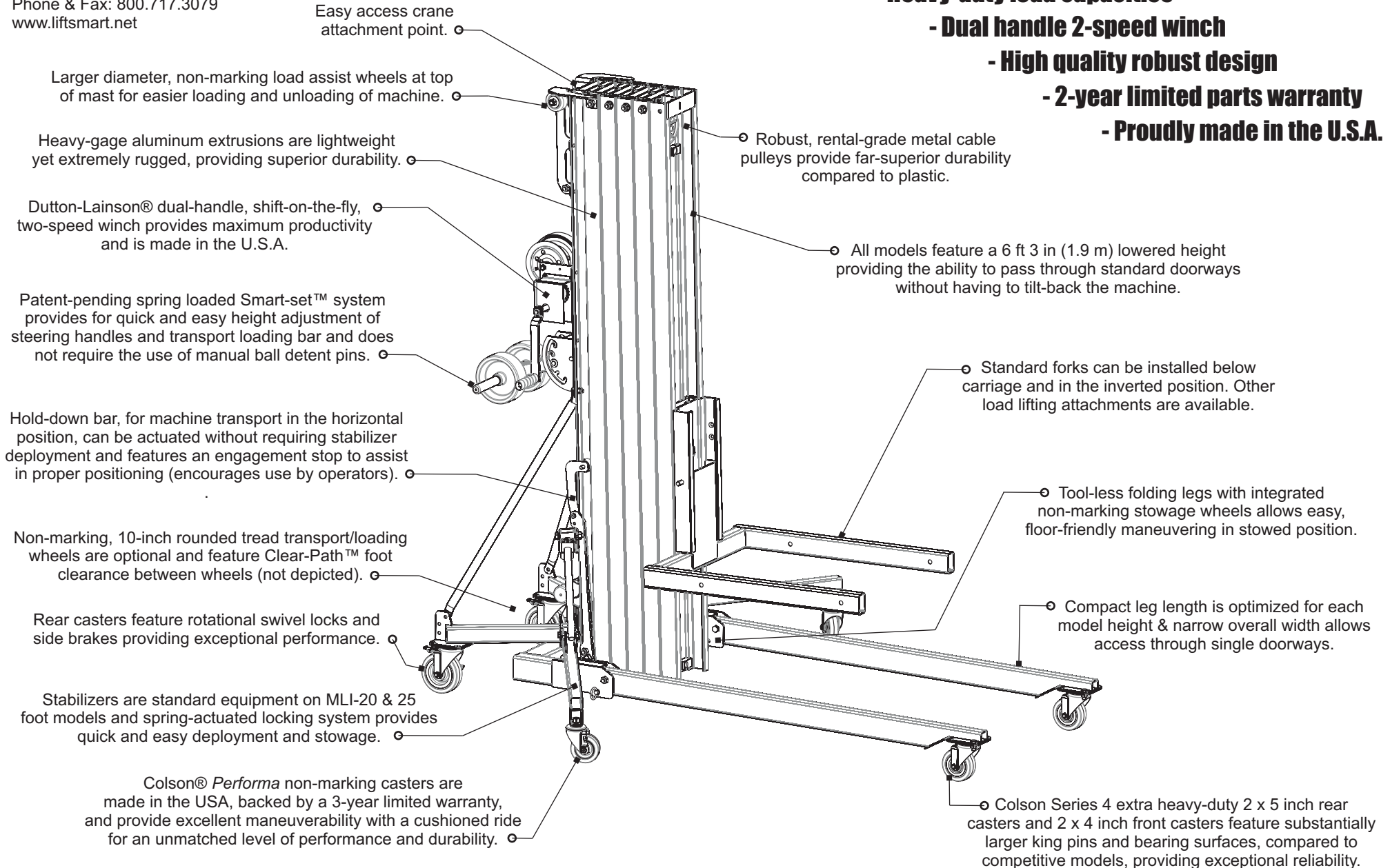

Easy access crane attachment point.

Larger diameter, non-marking load assist wheels at top of mast for easier loading and unloading of machine.

Heavy-gage aluminum extrusions are lightweight yet extremely rugged, providing superior durability.

Dutton-Lainson® dual-handle, shift-on-the-fly, two-speed winch provides maximum productivity and is made in the U.S.A.

Patent-pending spring loaded Smart-set™ system provides for quick and easy height adjustment of steering handles and transport loading bar and does not require the use of manual ball detent pins.

Hold-down bar, for machine transport in the horizontal position, can be actuated without requiring stabilizer deployment and features an engagement stop to assist in proper positioning (encourages use by operators).

Non-marking, 10-inch rounded tread transport/loading wheels are optional and feature Clear-Path™ foot clearance between wheels (not depicted).

Rear casters feature rotational swivel locks and side brakes providing exceptional performance.

Stabilizers are standard equipment on MLI-20 & 25 foot models and spring-actuated locking system provides quick and easy deployment and stowage.

Colson® Performa non-marking casters are made in the USA, backed by a 3-year limited warranty, and provide excellent maneuverability with a cushioned ride for an unmatched level of performance and durability.

Robust, rental-grade metal cable pulleys provide far-superior durability compared to plastic.

All models feature a 6 ft 3 in (1.9 m) lowered height providing the ability to pass through standard doorways without having to tilt-back the machine.

Standard forks can be installed below carriage and in the inverted position. Other load lifting attachments are available.

Tool-less folding legs with integrated non-marking stowage wheels allows easy, floor-friendly maneuvering in stowed position.

Compact leg length is optimized for each model height & narrow overall width allows access through single doorways.

Colson Series 4 extra heavy-duty 2 x 5 inch rear casters and 2 x 4 inch front casters feature substantially larger king pins and bearing surfaces, compared to competitive models, providing exceptional reliability.

NEARLY 100% U.S. CONTENT
INVEST IN AMERICA - CHOOSE LIFTSMART



Mini-Pro Series

Transportable in SUVs, vans, and short-bed pick-up trucks

- Industry-leading transportability

- Dual handle 2-speed winch

- High quality heavy duty design

- 2-year limited parts warranty

- Proudly made in the U.S.A.

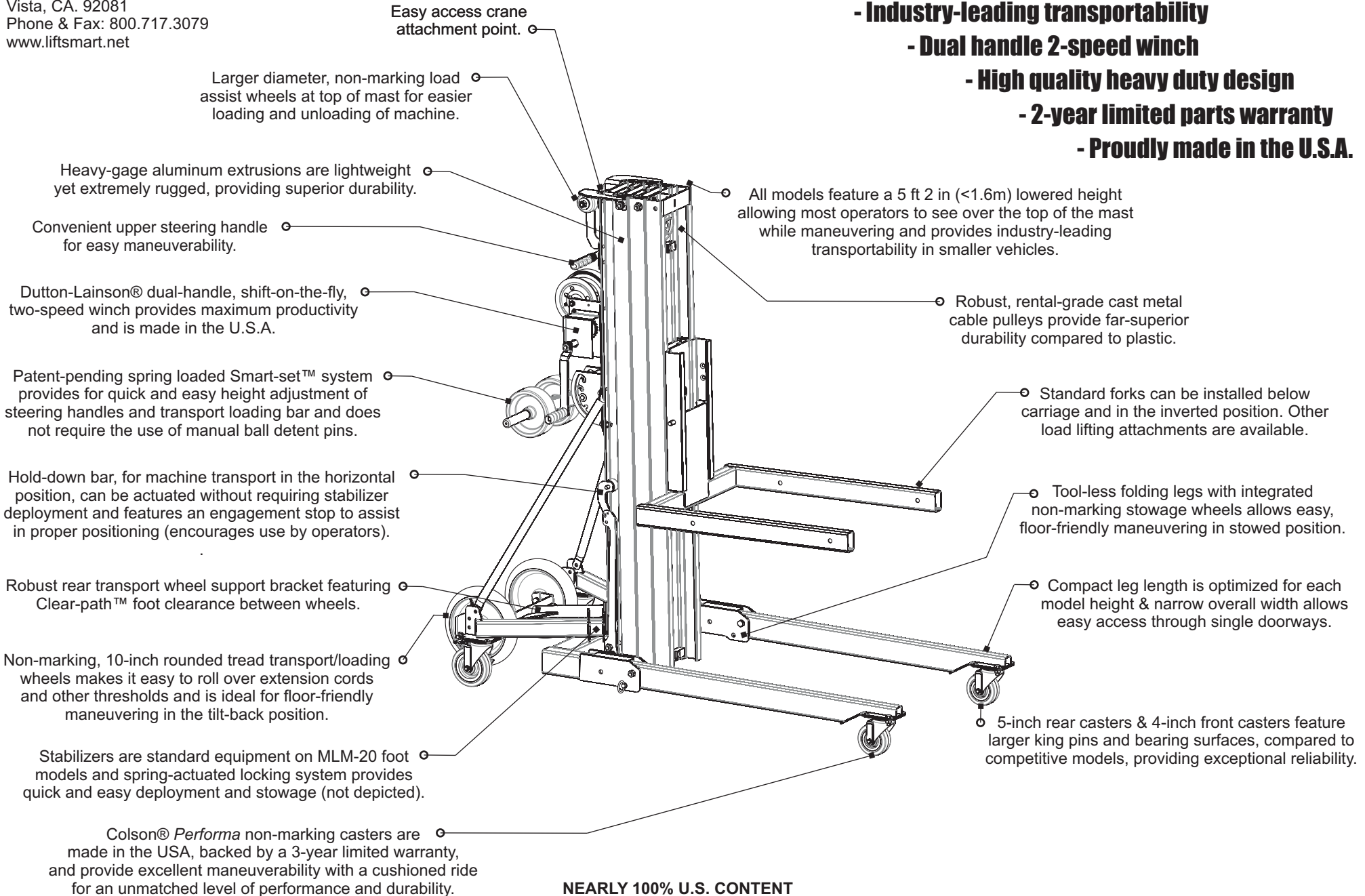

Easy access crane attachment point.

Larger diameter, non-marking load assist wheels at top of mast for easier loading and unloading of machine.

Heavy-gage aluminum extrusions are lightweight yet extremely rugged, providing superior durability.

Convenient upper steering handle for easy maneuverability.

Dutton-Lainson® dual-handle, shift-on-the-fly, two-speed winch provides maximum productivity and is made in the U.S.A.

Patent-pending spring loaded Smart-set™ system provides for quick and easy height adjustment of steering handles and transport loading bar and does not require the use of manual ball detent pins.

Hold-down bar, for machine transport in the horizontal position, can be actuated without requiring stabilizer deployment and features an engagement stop to assist in proper positioning (encourages use by operators).

Robust rear transport wheel support bracket featuring Clear-path™ foot clearance between wheels.

Non-marking, 10-inch rounded tread transport/loading wheels makes it easy to roll over extension cords and other thresholds and is ideal for floor-friendly maneuvering in the tilt-back position.

Stabilizers are standard equipment on MLM-20 foot models and spring-actuated locking system provides quick and easy deployment and stowage (not depicted).

Colson® Performa non-marking casters are made in the USA, backed by a 3-year limited warranty, and provide excellent maneuverability with a cushioned ride for an unmatched level of performance and durability.

All models feature a 5 ft 2 in (<1.6m) lowered height allowing most operators to see over the top of the mast while maneuvering and provides industry-leading transportability in smaller vehicles.

Robust, rental-grade cast metal cable pulleys provide far-superior durability compared to plastic.

Standard forks can be installed below carriage and in the inverted position. Other load lifting attachments are available.

Tool-less folding legs with integrated non-marking stowage wheels allows easy, floor-friendly maneuvering in stowed position.

Compact leg length is optimized for each model height & narrow overall width allows easy access through single doorways.

5-inch rear casters & 4-inch front casters feature larger king pins and bearing surfaces, compared to competitive models, providing exceptional reliability.

**NEARLY 100% U.S. CONTENT
INVEST IN AMERICA - CHOOSE LIFTSMART**

Industrial Pro Straddle Base

Passes through standard doorways without tilting back

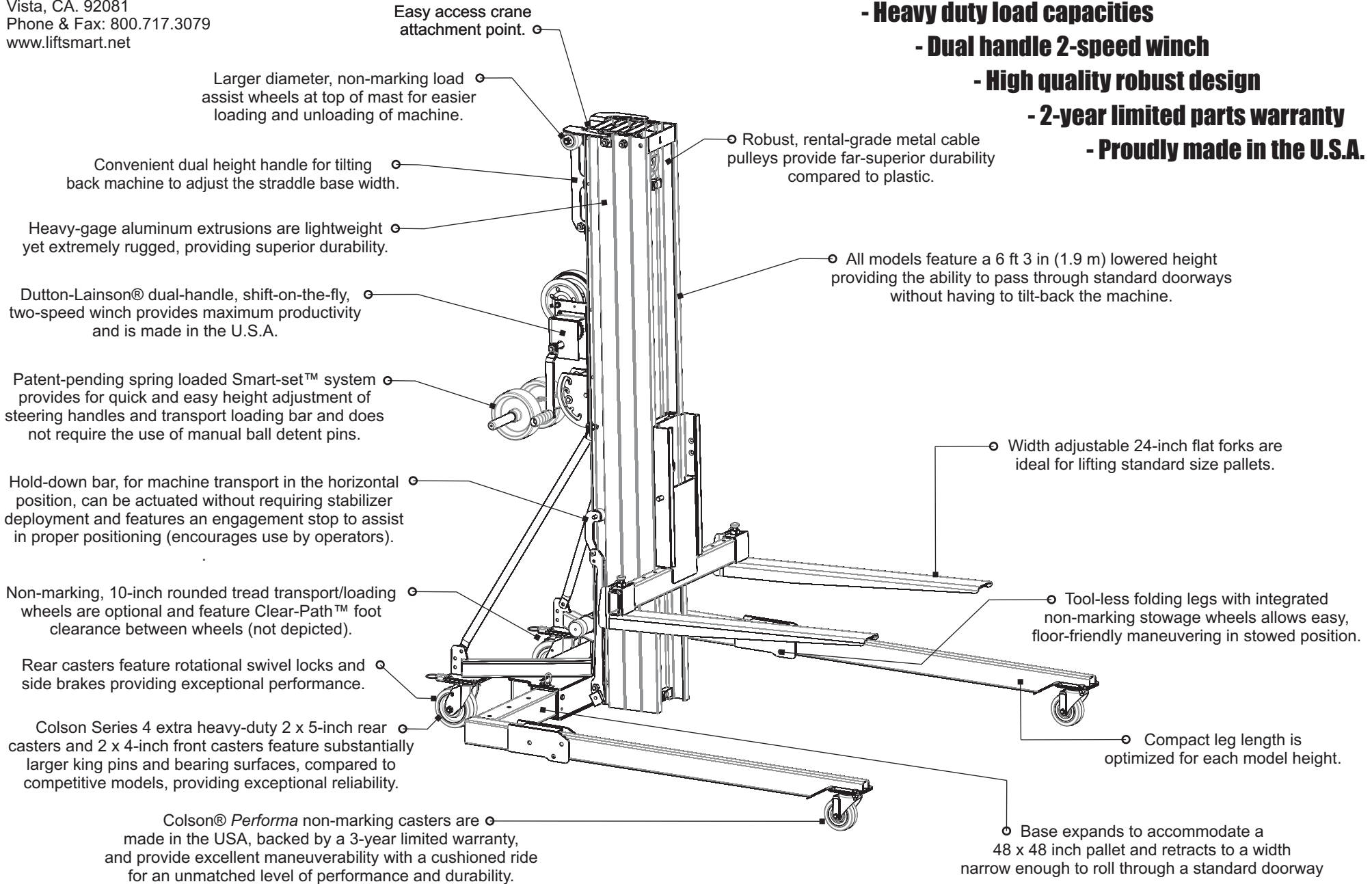

Easy access crane attachment point.

Larger diameter, non-marking load assist wheels at top of mast for easier loading and unloading of machine.

Convenient dual height handle for tilting back machine to adjust the straddle base width.

Heavy-gage aluminum extrusions are lightweight yet extremely rugged, providing superior durability.

Dutton-Lainson® dual-handle, shift-on-the-fly, two-speed winch provides maximum productivity and is made in the U.S.A.

Patent-pending spring loaded Smart-set™ system provides for quick and easy height adjustment of steering handles and transport loading bar and does not require the use of manual ball detent pins.

Hold-down bar, for machine transport in the horizontal position, can be actuated without requiring stabilizer deployment and features an engagement stop to assist in proper positioning (encourages use by operators).

Non-marking, 10-inch rounded tread transport/loading wheels are optional and feature Clear-Path™ foot clearance between wheels (not depicted).

Rear casters feature rotational swivel locks and side brakes providing exceptional performance.

Colson Series 4 extra heavy-duty 2 x 5-inch rear casters and 2 x 4-inch front casters feature substantially larger king pins and bearing surfaces, compared to competitive models, providing exceptional reliability.

Colson® *Performa* non-marking casters are made in the USA, backed by a 3-year limited warranty, and provide excellent maneuverability with a cushioned ride for an unmatched level of performance and durability.

- Heavy duty load capacities
- Dual handle 2-speed winch
- High quality robust design
- 2-year limited parts warranty
- Proudly made in the U.S.A.

Robust, rental-grade metal cable pulleys provide far-superior durability compared to plastic.

All models feature a 6 ft 3 in (1.9 m) lowered height providing the ability to pass through standard doorways without having to tilt-back the machine.

Width adjustable 24-inch flat forks are ideal for lifting standard size pallets.

Tool-less folding legs with integrated non-marking stowage wheels allows easy, floor-friendly maneuvering in stowed position.

Compact leg length is optimized for each model height.

Base expands to accommodate a 48 x 48 inch pallet and retracts to a width narrow enough to roll through a standard doorway

NEARLY 100% U.S. CONTENT
INVEST IN AMERICA - CHOOSE LIFTSMART